

Cheese Machinery and Solutions by

scansteel[®] foodtech





scansteel foodtech A/S is among the leading and most innovative companies, designing, engineering, manufacturing, installing, and servicing single machines and equipment as well as complete processing lines for the global food industries. As you will see throughout our latest “Cheese Machinery and Solutions” catalogue, scansteel foodtech A/S has a high focus on the global cheese processing industries.

Our core machinery competences are within grinders for fresh cheeses, frozen cheese and butter blocks, single- and twin shaft mixers, vacuum mixers, pumps all applications, pump and hopper fed emulsifiers, batching and weighing stations, and silo systems for all types of Heavy Duty food applications.

scansteel foodtech A/S’ portfolio of standard food preparation machines and equipment comprises a total of approximately 140 standard machines and equipment.

In addition to our standard range of food preparation machines and equipment, scansteel foodtech A/S develops individually tailor-made machines and equipment in co-operation with our customers.

Our food processing lines can be delivered with or without Line Control Systems, with or without recipe formulation software, uploading of data to customers’ existing ERP systems, and MCC’s.

scansteel foodtech A/S is a 100% privately owned, Danish company (Europe, Scandinavia). scansteel foodtech A/S resides in the former 10.450 m² Wolfking® domicile in the city of Slagelse 1 hour from Copenhagen airport.

Feel free to contact scansteel foodtech A/S for a mutual conversation concerning any food preparation processing need you may have, now or in the future.



View over scansteel foodtech® final assembly hall.

Table of Contents

Introduction	2
Cheese Industry Products	
A) Pasteurized Processed Cheese	5
B) Pasteurized Processed Cheese Food	5
C) Pasteurized Processed Cheese Spread	6
D) Cold Pack Cheeses	6
E) Cheese Sauce	7
F) Spray Dried Cheese	7
Example of Final Cheese Product - End User	8
Cheese & Butter Extruders MGX 250/300/400	9-10
Whole Pallet Crushers/Pre-breakers	11
Whole Pallet Crusher - Single	11-12
Whole Pallet Crusher - Twin	13-15
Block Crusher	
Discharge Feed Unit & Discharge Pump System for scanStructor	16
scanStructor	17
Grinders - Single Worm Grinders	18
MG 200, 250 & 225	19-21
MG 330	22
MG 400 & MG 400 Heavy Duty	23-24
Grinders - Double Worm Grinders	26-29
Mixers	30-35
Pumps	36
ContiPump	36-38

Danish quality
equipment conceived,
engineered, and
manufactured in
Denmark

Cheese Pump Grinder Head	39
Final Emulsifier FE 250	40
Storage & Batching	41-43
Product Transfer Equipment	
Infeed Systems for Grinders - Frozen Blocks	44-45
Infeed Systems for Grinders - Fresh Meat Raw Materials	46-47
Discharge Systems for Grinders	48-49
Screw Conveyors	50-51
scanLift	52-55
scanSwing	56
Line Control System	57
Global Team	58-64

scansteel foodtech A/S specializes in machinery, equipment, and complete processing lines.

A Pasteurized Processed Cheese

Pasteurized Processed Cheese is typically being produced by using one or more natural cheeses that are mixed/blended with other ingredients to produce a high value final product. These kinds of cheeses typically have a smooth, creamy texture that melts without oiling off. These cheeses have a high content of natural cheese blended with other ingredients to help extend the shelf life and flavour of the product.



Example of typical applications is Queso, sauces and soups.



Example of typical applications could also be shredding of cheese into soups and/or eggs.



B Pasteurized Processed Cheese Food

Pasteurized Process Cheese Food is a product that uses a combination of natural cheeses with other dairy and non-dairy ingredients. Possibly, this product may possibly also contain a high content of natural cheese making it very flavourful and rich in taste.



C Pasteurized Processed Cheese Spread

Pasteurized Process Cheese Spread is a blend of natural cheeses and other dairy and non-dairy ingredients. This product may contain sweeteners and stabilizing ingredients to ensure lengthening of shelf life and freshness. A range of moisture levels allow for a wide variety of products such as loaves, slices, and spreads.



D Cold Pack Cheeses

Cold pack cheese products are blends of natural cheeses and other ingredients that are not cooked. The spreadable cheeses are perfect additions to crackers and veggies etc. There are countless options for flavours and types of cheese that can be used.



E

Cheese Sauce

Typically distributed as “Boil in the Bag Cheese Sauce” that can be used to spice up appetizers, pastas, and other dishes.



F

Spray Dried Cheese

Whether you produce Cheese Powders and/or Cheese Powder Blends, we feel assured that scansteel foodtech A/S has the right know-how and know-why, to find the right solution, in cooperation with your company, for your cheese processing machinery/equipment.



EXAMPLE OF FINAL CHEESE PRODUCTS - END USER

**Cheese Sticks and
Chili Cheese Tops**



Ready Meals with Cheese



Cheese & Butter Extruder Series



CHEESE & BUTTER EXTRUDER SERIES MGX 250/300/400

scansteel foodtech A/S manufactures and supplies a range of cheese extruders, model MGX 250/300/400, respectively. Extruders can be supplied as stand-alone equipment or as part of an entire cheese processing line. High output to meet high production rate demands up to 12,000 kg/hr. Lower formulation costs as high surface area/small particle size of $\varnothing 2.8/$ $\varnothing 5$ or $\varnothing 14$ mm lead to increased utilisation of functional components, i.e. young cheese intact casein due to increased and consistent melting and protein hydration/emulsification capabilities. Minimum risk of foreign matter: no metal-to-metal contact surfaces because of foreign matter separation. Performance capability: high output up to 12,000 kg/hr and particle size $\varnothing 2.8$, $\varnothing 5$ or $\varnothing 14$ mm. Capable to extrude frozen cheese and butter.



Cheese Extruder in operation.



Cheese extrusion filter comes with varied filter sizes, typically $\varnothing 2.8$, $\varnothing 5$ and $\varnothing 14$ mm.



Close-up of extruded cheese, view 1 (one).



Close-up of extruded cheese, view 2 (two).



Close-up of extruded cheese, view 3 (three).



Front view of scansteel foodtech® MGX 400 Cheese and Butter Extruder shown in production ready mode.

Cheese & Butter Extruder Series

CHEESE & BUTTER EXTRUDER SERIES MGX 250/300/400



Extruder filter shown without safety cover.



Extruder filter shown with safety cover.



Extruder filter shown with top safety cover.



Cheese feed guide shown right mounted.
Electro polished feeding worm/auger, also shown.



Assembly/
disassembly trolley
in stainless steel
execution.



Accessory trolley for all loose parts.

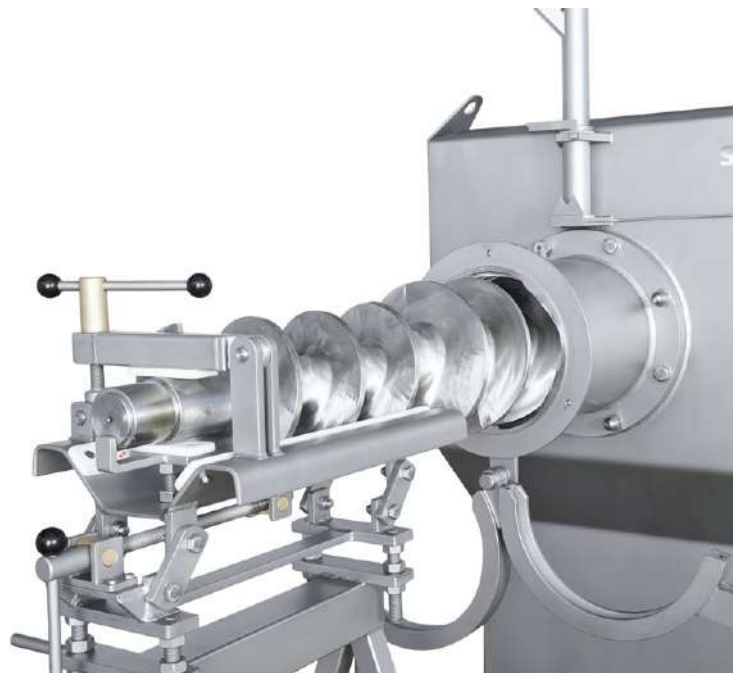

Whole Pallet Crushers/Breakers

WPC 2000-SINGLE & WPC 2000-TWIN

The scansteel foodtech® Whole Pallet Crusher, WPC, range is probably among the most comprehensive ranges available. The entire cabinet and frame structure is manufactured in stainless steel AISI 304. The WPC is available with single or double rotary claw shafts. The infeed width is available in either 1500 mm or 2000 mm. The Heavy Duty design is performed with main bearing positioned on each side of the claw shaft ends thus eliminating all axial forces between the claws and gear box



Whole Pallet Crushers/Breakers

WPC 2000-SINGLE & WPC 2000-TWIN



Bottom picture : Please note the shock absorbers which allow the WPC to remain stable (not moving) even when the WPC is fed by a fork lift truck dumping whole pallets into the crusher cabinet.



Top picture: Heavy Duty safety clutch claw and gear box.
Bottom picture: The rotary and stationary claw design comes in two versions.

SET OF STATIONARY CLAWS

Fixed onto the cabinet as counter claws to the rotary claw shaft. Each stationary claw is welded onto both sides of the rotary claw shaft.

Available Dimensions of Claw(s):	A	B
Thickness of rotary claw(s), on claw tip	65 mm	45 mm
Thickness of rotary claw(s)	60 mm	40 mm
Distance between stationary claw(s)	80 mm	



Whole Pallet Crushers/Breakers

WPC 2000-SINGLE & WPC 2000-TWIN

scansteel foodtech A/S manufactures a range of Whole Pallet Crushers with either single claw or double claws with a standard infeed width of 2000 mm. A Whole Pallet Crusher is capable of crushing a pallet full of frozen together blocks which as such appear as one entire frozen block of, example only, 1200 x 800 x 1500 mm.



Heavy Duty bearings – on each end of the crusher claw(s). Absorbing/eliminating all axial forces between claw(s) and gear box.

The entire infeed hopper is manufactured in 20 mm stainless steel plate AISI 304.

scansteel foodtech®
Whole Pallet Crusher,
WPC 2000-Single,
is shown on picture
below.

FEATURES:

- Constructed in 20 mm stainless steel plate AISI 304.
- Infeed hopper and discharge frame/hopper manufactured according to customer requirements/demands.
- Crusher claw(s) made of hardened material.
- Designed with few spare and wear parts leading to very low operation and maintenance costs for the machine.
- Frozen block dimensions: 1000 x 1000 x 1000 mm.
- WPC 2000-Single, 10,000 – 20,000 kg/hour (22,000 – 44,000 lbs./hour). Power/motor 37 / 45 / 55 / 75 kW
- WPC 2000-Twin, 20,000 – 60,000 kg/hour (44,000 – 130,000 lbs./hour). Power/motor 37 / 45 / 55 / 75 kW – 2 x 110 kW.
- Bearing on each end of crusher claw(s).



Whole Pallet Crushers/Breakers



Crusher claw(s) made of mild steel with hard ended claw tips.



Planetary gear box assembly. Between gear box and crusher claw, a Heavy Duty clutch system prevents damage to the gear box in case a large foreign (metal) object by mistake is thrown into the Whole Pallet Crusher.



scansteel foodtech[®] Whole Pallet Crusher, WPC 2000-Single, shown in application where existing footprint is sparse and where the pre-broken frozen blocks must be elevated to approx. 5000 mm.

Below: Picture shows the 2000 mm wide inlet/infeed hopper. The hopper is typically loaded by a fork lift truck, a lifting device, or an inclined belt conveyor.



Final installation of Whole Pallet Crusher, WPC 2000-Single, at customer site, shown with platform with ladder.



Horizontal screw shown with closed lid.

Whole Pallet Crushers/Breakers



Whole Pallet Crusher, WPC 2000 perfectly integrates with complete pet food processing lines. WPC 2000 shown with a scansteel foodtech® inclined screw conveyor with built-in buffer capacity for a crushed whole pallet of meat raw materials.

The claws for the WPC 2000 can optionally be delivered with claws of mirror polished stainless steel.



Buffer hopper with mounted weighing cells for batch control and automatic start/stop of machinery.



View of the belt transmission.



Top view looking at the inside/ineed section where the whole pallets of meat raw material will be fed into the WPC 2000.

Block and Barrel Crusher Series

SCANSTEEL FOODTECH[®] SCANSTRUCTOR

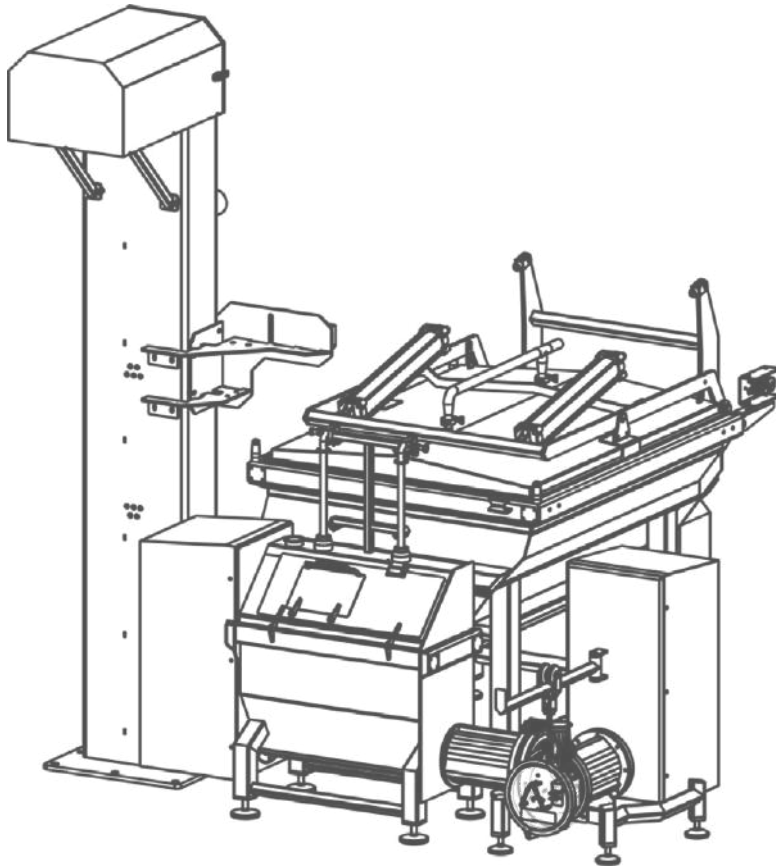

scanstructor fully assembled
- scanstructor, Discharge Feed Unit
and Discharge Pump.

scanstructor shown with pneumatic lid. Lid for
cleaning/soaking of scanstructor including CIP
(Cleaning in Place) nozzles.

Cleaning/soaking lid is delivered in 2 (two)
versions: Sliding lid or rear hinged lid.

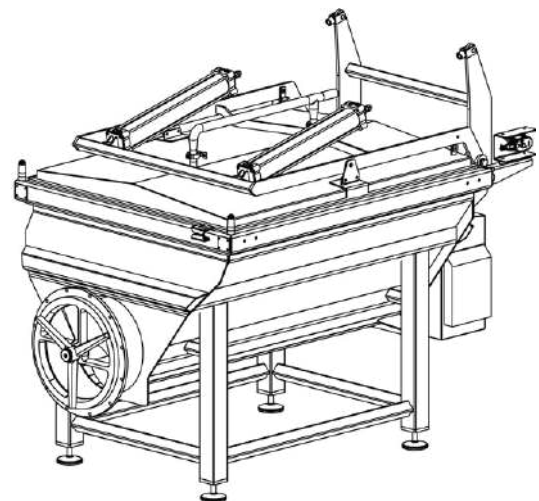

scansteel foodtech[®] scanstructor.



Discharge Feed Unit for scanstructor.



Discharge Pump for scanstructor.

Block Crusher

SCANSTEEL FOODTECH® SCANSTRUCTOR

The scansteel foodtech® scanSTRUCTOR is a Heavy Duty block crusher for crushing of individual frozen meat raw material blocks. Typical application is that the scanSTRUCTOR is fed by individual frozen blocks.



Front view of the
scanSTRUCTOR.
Outlet Ø600 mm.



The scanSTRUCTOR is typically equipped with a 37 kw motor.



scansteel foodtech® scanSTRUCTOR top view, showing the infeed
hopper with heavy duty crushing claws.



Showing rear left view with hygienic zone.

GRINDERS – SINGLE WORM

Over the years, the scansteel foodtech Group has conquered the position as THE supplier with the world's widest and most comprehensive grinder programme. scansteel foodtech A/S delivers, among others, the following grinder programme:

- Cabinet Grinders ranging from Ø200 mm – Ø550 mm (Ø8" – Ø22") – 22 kW – 200 kW (type name: MG).
- Open Cabinet Grinders ranging from Ø200 mm – Ø550 mm (Ø8" – Ø22") – 22 kW – 200 kW (type name: MG Low).



SINGLE WORM/AUGER GRINDERS:

MG 400 Super Heavy Duty, Brutalis	160 - 200 kW
MG 400 Heavy Duty	132 - 160 kW
MG 400	90 - 110 kW
MG 330	75 - 90 kW
MG 250	55 kW
MG 225	37-45 kW
MG 200	30 kW

FEATURES:

- Constructed in stainless steel AISI 304.
- Grinders from Ø200 mm – Ø550 mm.
- Grinding capacities from 2000 – 40,000 kg/hour.
- Large hopper infeed area preventing bridge building.
- Low noise level.
- Low energy consumption.
- 75 kW – 250 kW motor.
- 1 or 2 units dismantling crane.
- Heavy Duty construction.

GRINDER – SINGLE WORM: MG 200 & MG 250

The scansteel foodtech® MG 200 & MG 250 grinders are specially designed for fresh meat and fresh meat raw materials as well as for pre-broken/crushed frozen blocks.



Infeed hopper secured by trip wire. When safety devices have been triggered, they will stop the machine after maximum of 4 (four) seconds.

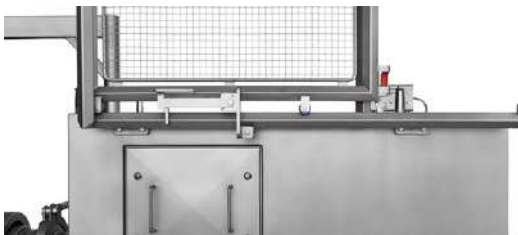

*Top picture: Safety guard for platform shown in running position.
Bottom picture: Safety guard for platform shown in open/cleaning/inspection position.*

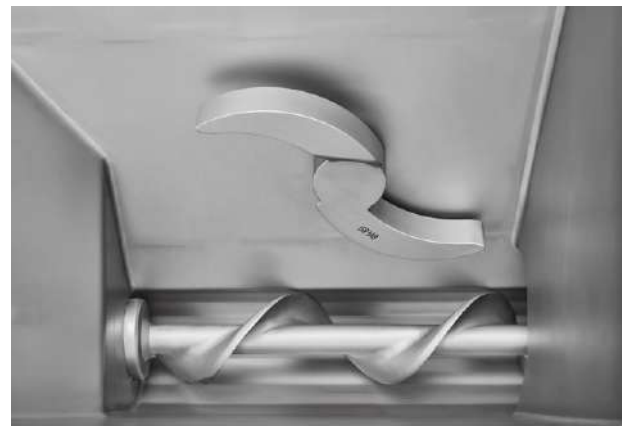

Stirring/feeding device. To secure continuous infeed of difficult/sticky meat raw material at the grinder worm/auger.

Grinders

GRINDER – SINGLE WORM: MG 200 & MG 250



Top picture: Assembly of SINGLE knife set including grinding worm/auger.

Bottom picture: Assembly of DOUBLE knife set including grinding worm/auger.



Accessory/cleaning trolley with space for all loose grinder parts.

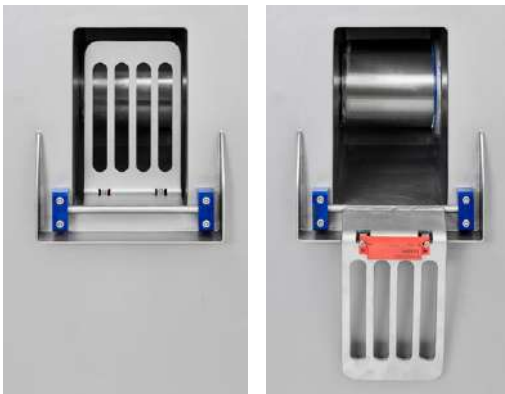

A prime example of scansteel foodtech® hygienic design is given by the hygienic zone positioned between the worm/auger and the gear box. Hygienic zone shown in running position (closed) and in cleaning/inspection position. When opened, the grinder cannot be started until the guard has been positioned in closed position.

MG 200 shown with back panel open. All stainless steel construction, including bottom frame.



GRINDER – SINGLE WORM: MG 225 - FOR FRESH RAW MATERIAL AND FROZEN BLOCKS

The scansteel foodtech® MG 225 Frozen Block Grinder is incredibly strong despite its compact size and it combines efficient processing with quality grinding. The MG 225 is specifically designed to grind whole frozen blocks and is perfect for grinding of fresh meat raw material as well. The MG 225 Frozen Block Grinder is equipped with a 45 kW motor, and it maintains a low operating cost and a low energy consumption for daily production. But without compromising on scansteel foodtech's well-known high quality standards, such as high hygienic design, operating safety, and performance.



The scansteel foodtech®
MG 225 Frozen Block Grinder



Operator panel



Top view of infeed hopper of the MG 225



Accessory/cleaning trolley with space for all loose grinder parts.



The scansteel foodtech® MG 225 is designed to be fed by either a belt conveyor or a lifting, here shown being fed by the scanLift SC 350 with 220 L trolley.

GRINDER – SINGLE WORM MG 330

The scansteel foodtech® MG 330 is equipped with either 75 kW or 90 kW electrical motor depending on specific grinding application(s). The MG 330 grinder is incredibly strong and reliable for both frozen blocks of meat raw material of any type as well as for certain bone-in products plus fresh meat raw materials. It comes with either a fixed or a loose pre-cutter depending on the grinding application.



Infeed hopper shown from top view. Please note the grinding worm/auger with the sharp knife edge, designed to grab and feed both frozen blocks and fresh meat raw materials.

MG 330 shown with standard operator panel with MINIMAL electrical/ electronic parts. Please note the safety guard is in open/disassembly position.



MG 330 shown with optional flange mounted extension infeed hopper and trip wire.

MG 330 shown in mounting position. The cleaning trolley for worm/auger shows/ indicates how to dismount the worm/auger, while avoiding heavy lifts/pulls.

Grinders

GRINDER – SINGLE WORM: MG 400 & MG 400 HEAVY DUTY

The scansteel foodtech® MG 400 & MG 400 Heavy Duty grinders are incredibly strong and reliable grinders for both frozen blocks of meat raw material of any type as well as for certain bone-in products plus fresh meat raw material. They come with either a fixed or a loose pre-cutter depending on the grinding application.



MG 400 Heavy Duty shown in disassembled position and with all loose parts positioned on accessory/ cleaning trolley for inspection and cleaning prior to assembly.



Infeed hopper shown from top view.



Hygienic zone shown in 3 (three) positions: running position (closed) and cleaning position shown from both angles.

scansteel foodtech® MG 400 Standard LOW and MG 400 Heavy Duty LOW. Grinder without cabinet. Shown with scansteel foodtech® hydraulic knife tensioning system.



Grinders

GRINDERS – SINGLE WORM: MG 400 & MG 400 HEAVY DUTY



Optional Extra, Example Only:
scansteel foodtech® worm/auger.

Please note: Worm/auger is not
included in the price of cleaning
trolley for worm/auger.



Cleaning trolley for worm/auger shown
without worm/auger.



Cleaning trolley for worm/auger shown after
the worm/auger has been removed from
grinder.

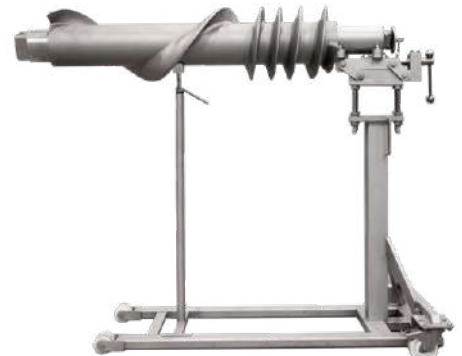

Cleaning trolley for worm/auger shown with
safety shaft mounted for cleaning, inspection,
and transport.



MG 400 worm/auger.



Heavy Duty designed worm/auger with sharp knife edge on hopper part of worm/auger to grab frozen blocks.



scansteel foodtech® accessory/cleaning trolley
shown with all loose parts for inspection and
cleaning.



Grinders



- SuperGrind 550/310 worm/auger.



- SuperGrind 400/260 worm/auger.



- MG 400 worm/auger.



- CG 300 grinding worm/auger.



- CG 300 feeding/breaking worm/auger.

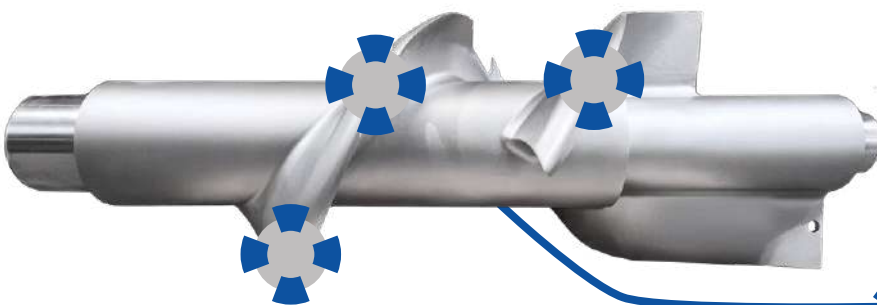

- CG 400 shark tooth worm/auger

For more information, please contact us!

Grinders - Double Worm

DOUBLE WORM COMBIGRIND CG 225 / CG 300 / CG 300 HEAVY DUTY / CG 400 – THE BEAST

These truly unique and universal grinders provide first-class grinding results, fully comparable with and even surpassing those of conventionally specialised grinders for fresh, tempered, or deep-frozen blocks without changing anything but the incoming raw material to be ground, coarsely or finely, as required. scansteel foodtech® CombiGrind Grinders from Ø160 mm – Ø400 mm (type name: CG).

CombiGrind CG 400
– The Beast



DOUBLE WORM/AUGER GRINDERS:

CombiGrind 400 Heavy Duty, The Beast	22 + 110 - 200 kW
CombiGrind 330 Heavy Duty	22 + 110 - 132 kW
CombiGrind 300 Heavy Duty	22 + 90 - 132 kW
CombiGrind 300	22 + 90 kW
CombiGrind 225	15 + 75 kW

High performance grinding within a wide capacity range is achieved through a low-tolerance, rigid design with smoothly shaped worms, hand-forged, welded, and ground superfinely by skilled Danish craftsmen combined with the smooth surfaces of a high precision CNC milling lining.



Grinders

DOUBLE WORM COMBIGRIND CG 225 / CG 300 / CG 300 HEAVY DUTY / CG 400 – THE BEAST



HYGIENIC ZONE

A prime example of scansteel foodtech® hygienic design is given by the two hygienic zones – one positioned between each of the worms/augers and one between the gear boxes.

Top picture: Details of the two unique hygienic zones for both top/feeding worm and bottom/grinding worm. This unique feature physically prevents cross contamination. Protected by safety grill and safety switch, which will stop the motor in three to four seconds from activation to full stop.



The electrical panel is embedded into the machine cabinet. The electrical panel can swing away to grant full access to the interior of the machine at maintenance, etc.

Grinders

COMBIGRIND CG 225 / CG 300 / CG 300 HEAVY DUTY / CG 400 – THE BEAST

CombiGrind CG 300 shown with automatic start/stop of grinder by level sensors built into front legs. CombiGrind CG 300 shown with 300 L extension hopper, which will be designed according to customer request and to be quoted separately.



Fresh soft meats as well as tempered or hard frozen blocks are efficiently processed jointly or separately without changing any mechanical components due to the ingenious design of hopper, transfer area between the worms/augers combined with efficient fixation of the frozen blocks. Narrow tolerances eliminate backwash, fines, or smearing.



Operator control with easy-to-understand push button operation of start, stop, and emergency. Pre-setting of worm/auger speeds and programming functions with logically designed graphics on the touch panel. Programmes with fixed settings for various products can be keyed in with password protection. The scansteel® scanControl function can be set to optimize the feeding worm/auger speed in relation to the grinding worm/auger, thus reducing grinding capacity flow fluctuations.

COMBIGRIND CG 225 / CG 300 / CG 300 HEAVY DUTY / CG 400 – THE BEAST



Removal of breaker worm/auger and grinding worm/auger. CombiGrind CG 400 – The Beast

Easy and efficient cleaning of both feeding worm/auger and grinding worm/auger, which can both be easily disassembled and removed together with other grinding tools by means of the included tool trolleys. Hole plates are easily removed and replaced during production with the included extraction tool, fitting the inner thread in the hole plate centre hole. The hygienic design provides easy access to and cleaning of all surfaces in contact with the product. The product area and drive components such as bearing etc. are completely separated by wide flushing channels with full visibility of and access to bearing sealings and drive clutches. This provides complete food safety as it is impossible for lubricants or bearing impurities to enter the product zone. Foldable safety fences prevent access to rotating parts during operation. All surfaces are either smoothly polished or ground and glass bead peened.



Removal of breaker worm/auger for CombiGrind CG 225, CG 300, CG 300 Heavy Duty.

MIXERS FROM 200 L - 12,000 L



scansteel foodtech® Twin Shaft Mixer, TSM(V) positioning on rack extension.



scansteel foodtech® Twin Shaft Mixer, TSM(V) positioning on floor.



Inside view of scansteel foodtech® Twin Shaft Mixer, TSM(V)

MIXERS: Side-by-side, TSM(V)

Twin Shaft Mixers

TSM - From 250 Litres – 12.000 Litres

Twin Shaft Mixers Vacuum

TSMV – From 250 Litres – 12.000 Litres

MIXERS: Intermeshing TSMI(V)

Twin Shaft Mixers

TSM - From 200 Litres – 12.000 Litres

Twin Shaft Mixers Vacuum

TSMV – From 200 Litres – 12.000 Litres

MIXERS: Single, SSM(V)

Single Shaft Mixers

SSM - From 250 Litres – 12.000 Litres

Single Shaft Mixers Vacuum

SSMV – From 250 Litres – 12.000 Litres

Mixers

MIXERS FROM 200 L - 12,000 L



scansteel foodtech® Twin Shaft Mixer, TSM(V) shown with back panel open, view of motors.



Close up view of load cells.



Close up view of operator panel with two hand JOG function for cleaning and inspection.



scansteel foodtech® Twin Shaft Mixer discharge gate system.

OPTIONAL EXTRAS: MIXER WING TYPES



Paddle wings.



Spiral mixing wings.



Paddle mixing wings, special application.

Single Shaft Mixers

SINGLE SHAFT MIXER – SSMV 1000 L - 12000 L



Single Shaft Mixer
SSMV 1000 L - 5000 L



scansteel foodtech® Single Shaft Mixer SSMV 1000 L - 5000 L, 15 kW including:

- Optional vacuum included if required in process.
- Bottom steam injection system with manifold, 6 (six) nozzles.
- Plate lid with CIP nozzles (Cleaning In Place nozzles).
- Load cell system: 4 (four) unit weighing cells and PROFINET weighing amplifier.

STEAM INJECT SYSTEM



Close up of scansteel foodtech® Bottom steam injection system shown on Twin Shaft Mixer, TSM(V)



Number of steam nozzles depending on mixer size.

MIXERS: Side by side, TSM(V)

Twin Shaft Mixers:

TSM - From 250 litres - 6250 litres

Twin Shaft Mixers Vacuum:

TSMV - From 250 litres - 6250 litres

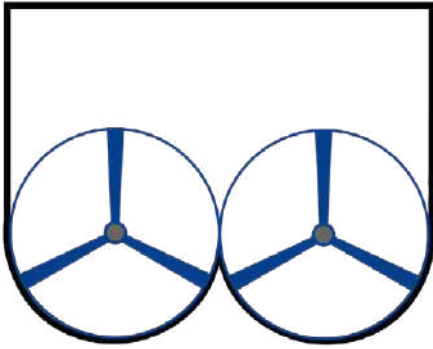

Left wing	Right wing	Wing rotation options for TSM(V) Series
		Left wing clockwise – Right wing clockwise
		Left wing counter clockwise – Right wing counter clockwise
		Left wing clockwise – Right wing counter clockwise
		Left wing counter clockwise – Right wing clockwise

MIXERS: Intermeshing TSMI(V)

Twin Shaft Mixers, Intermeshing:

TSMI - From 200 litres - 12,000 litres

Twin Shaft Mixers, Intermeshing Vacuum:

TSMIV - From 200 litres - 12,000 litres

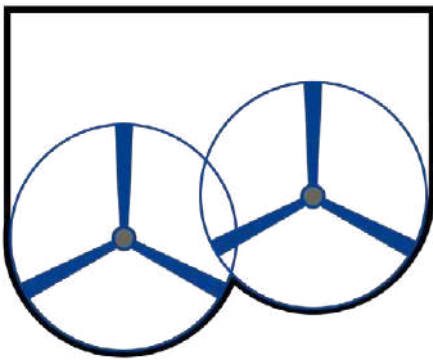

Left wing	Right wing	Wing rotation options for TSMI(V) Series
		Left wing clockwise – Right wing counter clockwise
		Left wing counter clockwise – Right wing clockwise

MIXERS: Single, SSM(V)

Single Shaft Mixers:

SSM - From 250 litres - 12,000 litres

Single Shaft Mixers Vacuum:

SSMV - From 250 litres - 12,000 litres



Left wing	Wing rotation options for SSM(V) Series
	Left wing clockwise – Right wing clockwise
	Left wing counter clockwise – Right wing counter clockwise

Features and Optional Extras

FEATURES:

- Constructed in stainless steel AISI 304.
- Safety equipment for CE conformity.
- Low energy consumption.
- Ideal for frozen meat and fresh/frozen mixtures. A flexible and high-performance mixing is given with both a high peripheral wing speed and a gentle handling of the mentioned raw materials.
- Minimum product residues and cross-mixing of batches, also including fully separated and sealed hygienic zone preventing any possible cross contamination.
- Various lid configurations: rear or side hinged. Optional as pneumatically operated.
- Computerized design of mixing wings and mixer geometry combined with the programmable mixing action ensures optimum processing results for you.
- Low noise level.
- Mixer controls available in range from ordinary push button operated versions to advanced PLC controlled systems. All PLC systems are supplied with reliable and easy accessible finger-touch operator panel with digital read-out of all mixer functions. Make Allen Bradley.

Features and Optional Extras

OPTIONAL EXTRAS:

- Dust lid without sealing
- Grill lid.
- Plate lid with sealing.
- Weighing system on frame.
- Weighing system, floor mounted.
- Frame prepared for weighing system.
- Temperature sensor (incl. in CO₂ and steam) – PT100.
- CO₂ top injection system with snow horns incl. control and lid.
- CO₂ bottom injection system.
- N₂ top injection system.
- N₂ bottom injection system.
- Steam bottom injection system incl. nozzles.
- Water dosing system, automatic.
- Double jacket for heating/cooling and insulation (not pressurized).
- Polished mixing container inside meat product zone.
- Interlock for trolleys - photo cell.
- Inspection platform, various executions.
- Mixing wings optional as standard paddle or spiral wings. Standard and paddle wings to run either side-by-side or intermeshing.

CONTIPUMP FROM 500 L – 10,000 L BUFFER HOPPER

The scansteel foodtech® ContiPump series is for less Heavy Duty applications such as, but not limited to, pre-mixes being fed into an emulsifier as well as for various buffer/storage/silo applications. The buffer hopper comes in 2 (two) versions: one single feeding screw or twin (two) feeding screws, where one screw feeds/drives the ContiPump while the other prevents/limits bridge building.



ContiPump 4000/250 Twin Screw
Shown fully assembled ready for
production. Shown with all safety
rails in position.

ContiPump 4000/250 Twin
Screw. The operator panel is
shown together with a level
control.

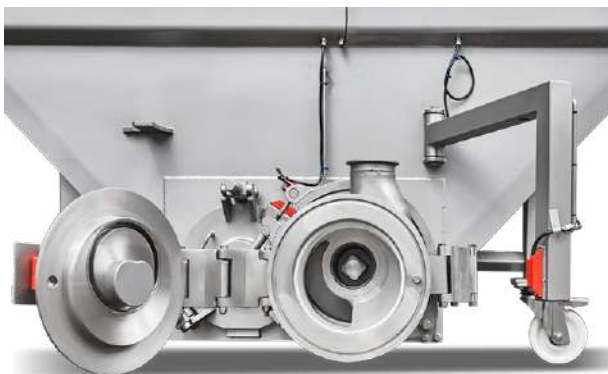

ContiPump pump housing, hinged.



Shown above: Close-up of pump housing and side panel for
second screw. Both designed for easy assembly/disassembly.

CONTIPUMP FROM 500 L – 10,000 L BUFFER HOPPER



Accessory/cleaning trolley for ContiPump.



Inside view of ContiPump 4000/250 Twin Screw. Can also be supplied with top stirring device.



The scansteel foodtech® ContiPump series has been designed in such a way that the unit can function as a stand alone pump or, as shown above, can be designed to fully be integrated as part of an integrated solution with the scansteel foodtech® ContiPump and the scansteel foodtech® mixer series. In order to secure full hygiene solutions as well as having full access to both the mixer(s) and ContiPump for inspection/maintenance. The scansteel foodtech® ContiPumps can be placed on a "rail system" which makes it fully possible for a person to separate the ContiPump and mixer. At the same time, during production, the ContiPump is secure in "running position" in such a way that the ContiPump cannot be moved.

CONTIPUMP:

Standard hopper sizes	250 - 4250 L
Gear motor for pump section	4- 11- kW
Gear motor for screw section	5,5 - 7,5 kW

CONTIPUMP FROM 500 L – 10,000 L BUFFER HOPPER

scansteel foodtech® ContiPump series comes in many different infeed hopper designs. Below shows a ContiPump being fed by a scansteel foodtech Mixer/Grinder.



Top view of the scansteel foodtech® ContiPump and Mixer/grinder.

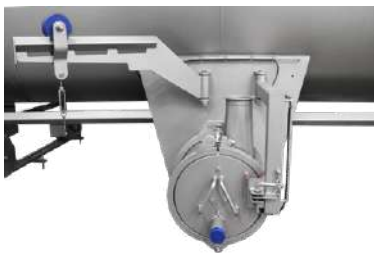

Cheese Pump Grinder Head

CHEESE PUMP GRINDER HEAD CPGH 250



*Cheese Pump Grinder Head
CPGH 250.*

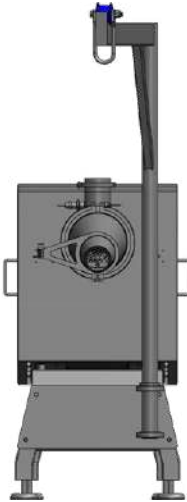
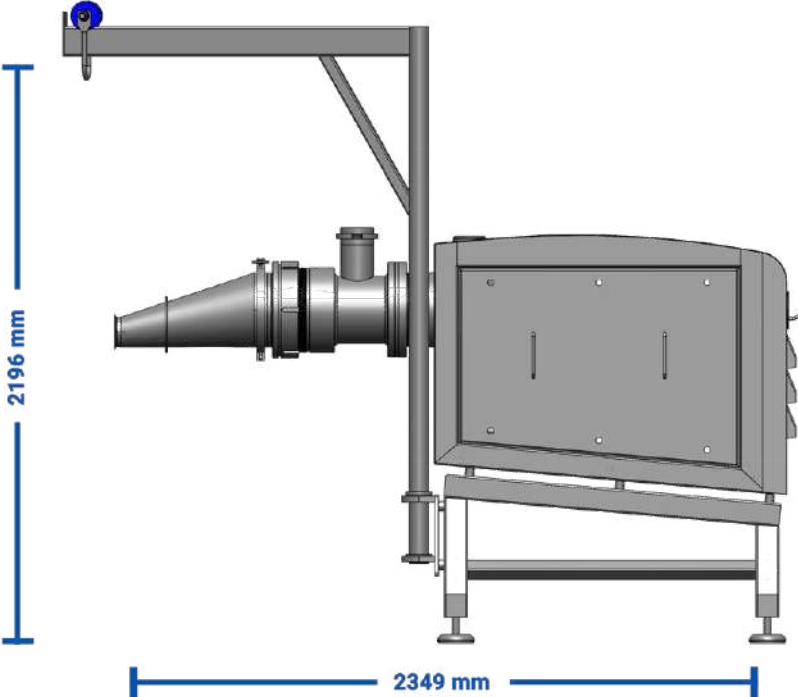

*Front view of
CPGH 250.*

Final Emulsifier

SCANSTEEL FOODTECH® FINAL EMULSIFIER FE 250

Final Emulsifier
FE 250.



The scansteel foodtech® Final Emulsifier FE 250 is pump fed or, alternatively, fed directly by a scansteel foodtech® emulsifier. The final emulsifier is typically used for final emulsifying of emulsions where particle size reduction needs to be at its maximum.

Typical motor size varies from 37 kW – 160 kW and production capacities typically vary from 4,000 – 20,000 kg/hour.



Storage & Batching Systems

SWING LOADER WITH WEIGHING BELT

This is a line consisting of typically 3-10 swing loaders which require 1 (one) person (operator) only. One person (operator) can semi-automatically/semi-automatically weigh out between 2-6 batches per hour and as such, the same person (operator) can quite easily feed a continuous processing line with two or more mixers.



6 (six) unit weighing station, seen from the infed side. Typically, Dolav bins are fed into the swing loaders by a fork lift truck. All is controllable from the operator panel.



6 (six) unit weighing station, seen from the batching/weighing side. The operator looks at the control panel to the right to check how many kilos he requires of a certain meat raw material. Next, the operator looks at the operator panels in front of each swing loader to see where he has to unload/weigh out the volume of the meat required. The weighing belt is equipped with 4 (four) load cells in order to monitor weights continuously.

Storage & Batching Systems

SWING LOADER WITH WEIGHT INDICATOR



Overview of the entire weighing and batching station, seen from the batching/weighing side.



Control panel for operator instructions in terms of next meat raw material to weigh out.



Details showing drip trays and weighing/load cells.



Line control of weighing and batching station.

Storage & Batching Systems

scansteel foodtech A/S has a wide range of different standard solutions for both weighing and batching applications. In addition, we do design and manufacture tailor-made systems according to customers' requirements and demands.



Belt conveyors with a range of standardized side rails and drip pans to avoid moisture and liquids on the floor.



All scansteel foodtech® belt conveyors can be equipped with weighing cells/ system for exact batching.



One option in the scansteel foodtech® "batching family of solutions" is a station of typically 2 – 8 swing loaders (tippers) which can hold different meat raw material.



With the scansteel foodtech® line control, it is possible to guide the operator into the exact amount of each meat raw material to be unloaded onto the weighing/batching belt conveyor.

INFEED SYSTEMS FOR GRINDERS - FROZEN BLOCKS - BELT CONVEYORS

scansteel foodtech A/S manufactures a wide range of belt conveyors. Except for a range of standard belt conveyors, scansteel foodtech A/S designs belt conveyors according to customer requests and requirements. All frames are manufactured in stainless steel, and belt types can vary to customer request and requirements. The scansteel foodtech® belt conveyors are driven by either drum motors or gear box motors, again according to customer requirements. In addition, belt conveyors can be equipped with metal detectors and/or blue plastic detectors.



Example of scansteel foodtech® infeed systems shown with belt conveyor, unpacking station and CombiGrind CG 300 HD



Belt Conveyor with unpacking station with 2 (two) lifting tables for ergonomics, left side.



Belt Conveyor with Unpacking station with 2 (two) lifting tables for ergonomics, right side.

INFEED SYSTEMS FOR GRINDERS - FROZEN BLOCKS - BELT CONVEYORS

Standard scansteel foodtech® inclined belt conveyor with metal detector for feeding a grinder. Shown with unpacking table with weighing/load cells for batching purposes.



Standard scansteel foodtech® inclined belt conveyor with metal detector, side view. scansteel foodtech A/S can deliver our belt conveyors with any brand type metal detector. Side view.



Standard scansteel foodtech® inclined belt conveyor with metal detector, Front top view. scansteel foodtech A/S can deliver our belt conveyors with any brand type metal detector. Front top view.

Product Transfer Equipment

INFEED SYSTEMS FOR GRINDERS - FRESH MEAT RAW MATERIAL - BELT CONVEYORS

Example of a scansteel foodtech® solution feeding fresh meat raw materials into a grinder with continuous metal detection. Fresh meat raw material is fed onto the belt conveyor via a scansteel foodtech scanSwing loader. This solution can also be supplied with a combined solution of both fresh- and frozen meat raw materials.



Top view of scanSwing loader and belt conveyor

Product Transfer Equipment

INFEED SYSTEMS FOR GRINDERS - BELT CONVEYORS

scansteel foodtech® inclined belt conveyor with metal detector, for feeding of frozen blocks, and automatic reject of frozen blocks being detected with metal pieces.

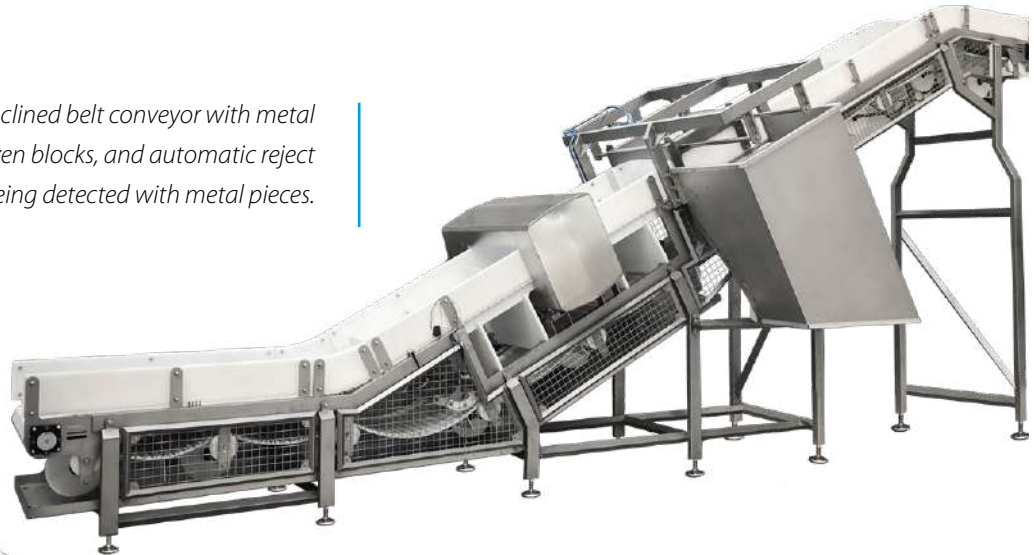

scansteel foodtech® inclined belt conveyor with metal detector.



Inclined belt conveyor with side racks.

DISCHARGE SOLUTION FOR GRINDERS - HORIZONTAL BELT CONVEYORS



Another typical horizontal belt conveyor solution where 2 (two) grinders are discharging onto the scansteel foodtech® belt conveyor. This solution saves a lot of safety devices and, at the same time, secures easy access to the grinders for cleaning, mounting, and dismantling of the grinders, front view.

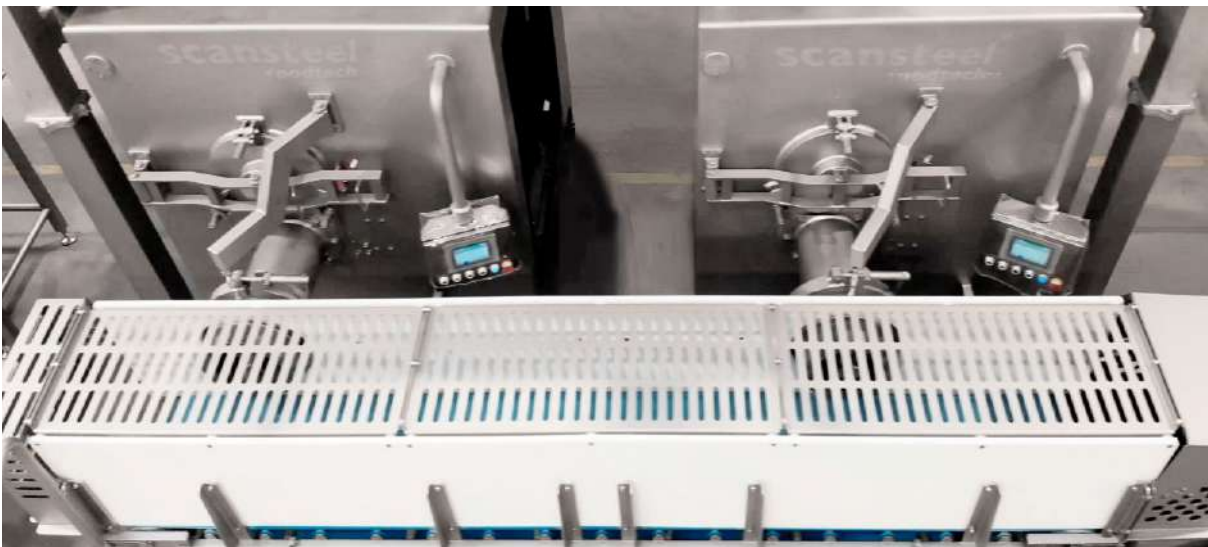

Another typical horizontal belt conveyor solution where two grinders are discharging onto the scansteel foodtech® belt conveyor. This solution saves a lot of safety devices and, at the same time, secures easy access to the grinders for cleaning, mounting and dismantling of the grinders, top view where the transfer point from grinders to belt conveyor is clearly seen.



All scansteel foodtech® belt conveyors can upon customers request be manufactured with drip trays/ collection pans in order to avoid moisture on the floor.

DISCHARGE SOLUTION FOR GRINDERS / FEEDING OF MIXERS -SCREW CONVEYOR & BELT CONVEYOR SOLUTIONS

scansteel foodtech A/S supplies various solutions where screw- and belt conveyors are combined. A typical solution might be discharging from one or two grinders into two or more mixers.



Close-up view showing scansteel foodtech® inclined screw conveyor feeding onto a scansteel foodtech® horizontal belt conveyor which has 3 (three) main positions.

This position shows the belt conveyor feeding a scansteel foodtech® mixer on left hand side.

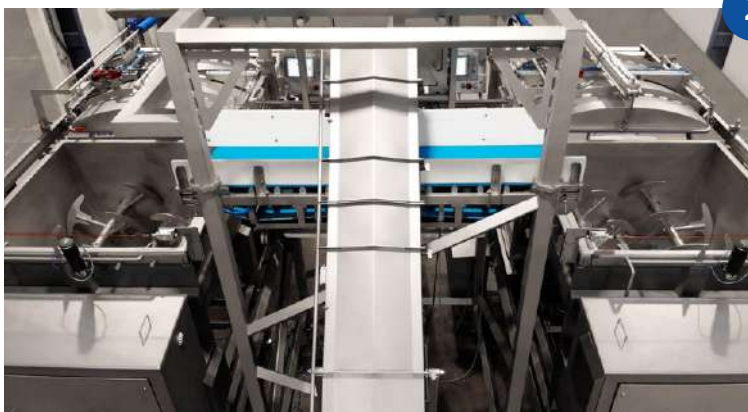

Close-up view showing scansteel foodtech® inclined screw conveyor feeding onto a scansteel foodtech® horizontal belt conveyor which has 3 (three) main positions.

This position shows the belt conveyor in neutral position in order for both mixer lids to be capable of closing.



Close-up view showing scansteel foodtech® inclined screw conveyor feeding onto a scansteel foodtech® horizontal belt conveyor which has 3 (three) main positions.

This position shows the belt conveyor feeding a scansteel foodtech® mixer on right hand side.

Product Transfer Equipment

SCREW CONVEYORS Ø240 - Ø600 MM - INCLINED, HORIZONTAL, AND VERTICAL SCREW CONVEYORS

From 1500 - 10,000 mm in length. scansteel foodtech A/S has a full range of standard designed screw conveyors. In addition, 100% tailor-made screw conveyors, designed according to customer request, are also available. As optional extras, the scansteel foodtech[®] range of screw conveyors can be supplied with or without hydraulic lifting and lowering systems.



Example of infeed section for grinder.



Heavy Duty shaft bearings shown.



Standard screw conveyor electrical/operator panel.



Please also note built-in drain plug for draining/cleaning purposes.

Product Transfer Equipment

SCREW CONVEYORS Ø240 - Ø600 MM

- INCLINED, HORIZONTAL, AND VERTICAL SCREW CONVEYORS



Inclined screw conveyor with hydraulic knockdown system for cleaning, inspection, and maintenance purposes.



Screw conveyor in knock down position ready for inspection and/or cleaning.

SCANLIFT SINGLE COLUMN

- FULL RANGE OF STANDARD LIFTING DEVICES FOR 200 - 300 L TROLLEYS



scanLift SC 350
shown with 220 L trolley.

scanLift SC 350
shown with 300 L trolley.



scanLift SC 350 with 220 L trolley shown in
discharge position. Equipped with discharge
chute/non-spill chute.



scanLift SC 350 electrical/operator panel.

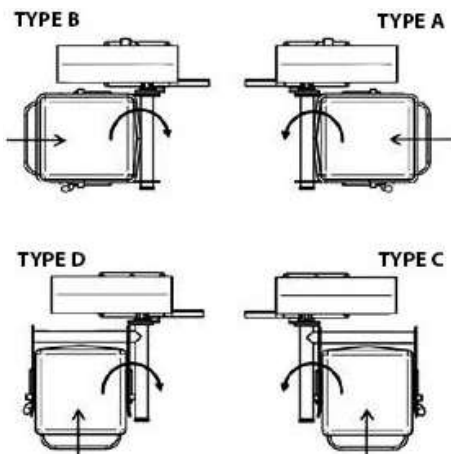

Type A and B Discharge Height in mm.	Type C and D Discharge Height in mm.
1400 – 1700	1400 – 1700
1700 – 2000	1700 – 2000
2000 – 2300	2000 – 2300
2300 – 2600	2300 – 2600
2600 – 2900	2600 – 2900
2900 – 3200	2900 – 3200
3200 – 3500	3200 – 3500
3500 – 3800	3500 – 3800
3800 – 4100	3800 – 4100

SCANLIFT SINGLE COLUMN

- FULL RANGE OF STANDARD LIFTING DEVICES FOR 200 - 300 L TROLLEYS



i Please contact us

Please contact scansteel foodtech A/S for special application/lifting devices for boxes, trolleys, and Dolav boxes.

*scanLift SC 350
shown with safety cage.*

*Special application
kettle/bowl.*



Product Transfer Equipment

SCANLIFT DOUBLE COLUMN

- ALL TYPES OF 220 - 300 L TROLLEYS AND BOXES/DOLAV BOXES

*Double column lifting device for plastic/metal crates/boxes.
– Dual function, shown with plastic crates/boxes.*



*Double column lifting device for plastic/metal crates/boxes.
– Dual function, shown with 200/300 L trolley.*



Detail showing how forks for 200/300 L trolley work combined with plastic/metal crates and boxes.

SCANLIFT DOUBLE COLUMN LOADER WITH PALLET INVERTER

This is the ultimate Heavy Duty Double Column Loader with built in hydraulic pallet inverter, scanLift has been designed for lifting/feeding of whole pallets of frozen blocks, containers of frozen blocks and similar applications. A typical application is feeding into the scansteel foodtech® whole Pallet Crusher, WPC series. The built in pallet inverter eliminates the need for at stand alone pallet inverter (depending of exact and specific application and customer needs/demand).



The scanLift Double Column loader with pallet inverter shown with all safety fences is running position.

The scanLift Double Column loader with pallet inverter shown in infeed position with safety gate open. Also the pallet inverter is shown. Typically the double column loader is loaded with a fork lift truck.



Product Transfer Equipment

SCANSWING LOADER

- scansteel foodtech A/S HAS A FULL RANGE OF SWING LOADERS

scansteel foodtech®
scanSwing
loader in down
position.



scanSwing loader
in empty position.



Machine feet which can be mounted
to the floor.



Operator/control panel with emergency
stop.

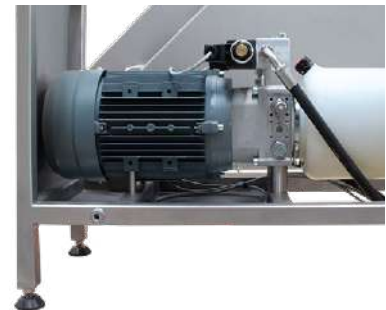

Inside view of hydraulic system.

Line Control System

scansteel foodtech® LINE CONTROL SYSTEMS

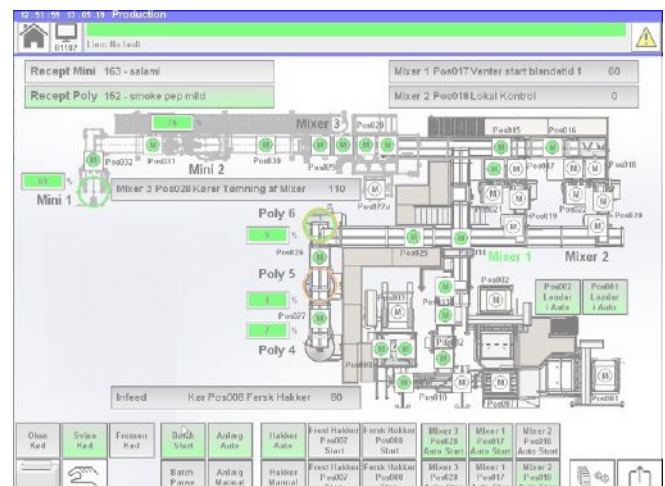
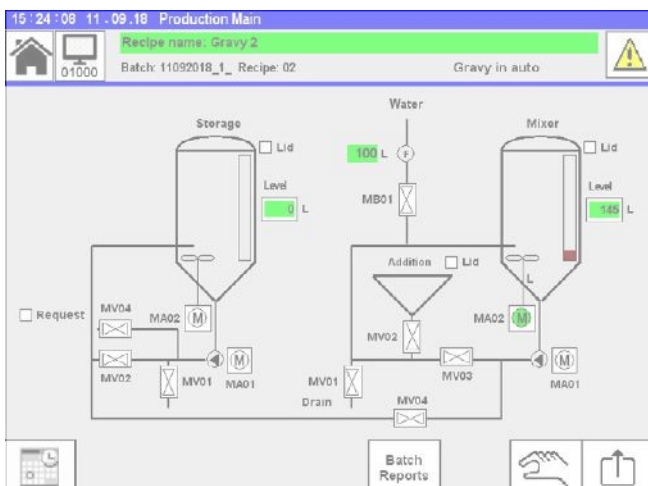
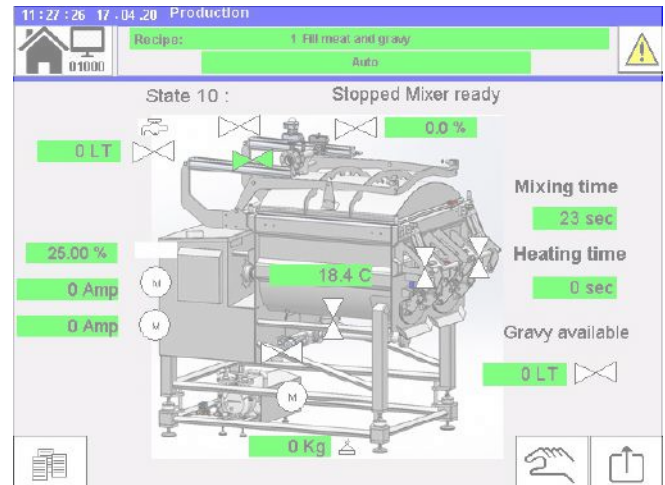
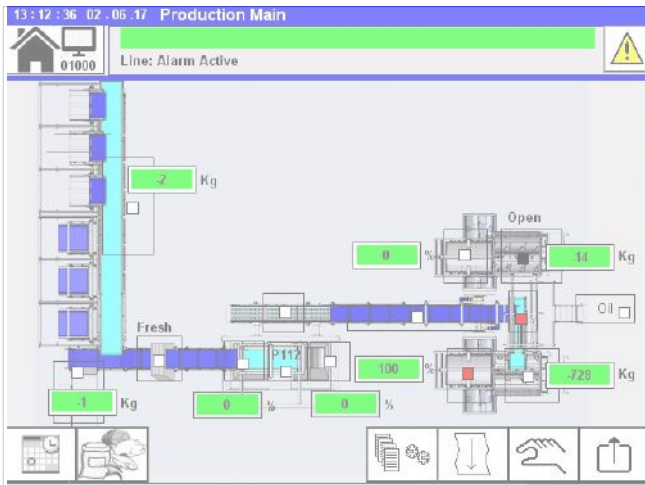

REMOTE ONLINE SUPPORT SYSTEM

EWON Module - To allow remote automation assistance from scansteel foodtech A/S.

When a scansteel foodtech® line is optionally equipped with a EWON module it is possible for scansteel foodtech A/S to go into the PLC via internet connection by an EWON Module. This makes it possible to offer the best and quickest service.



Our Global Agents & Distributors

HIGHLIGHTED BLUE AREAS SHOW GEOGRAPHIC LOCATION OF scansteel foodtech® AGENTS AND DISTRIBUTORS.

27 AGENTS & DISTRIBUTORS

SPREAD OVER 6 CONTINENTS

ACTIVE IN 55 COUNTRIES

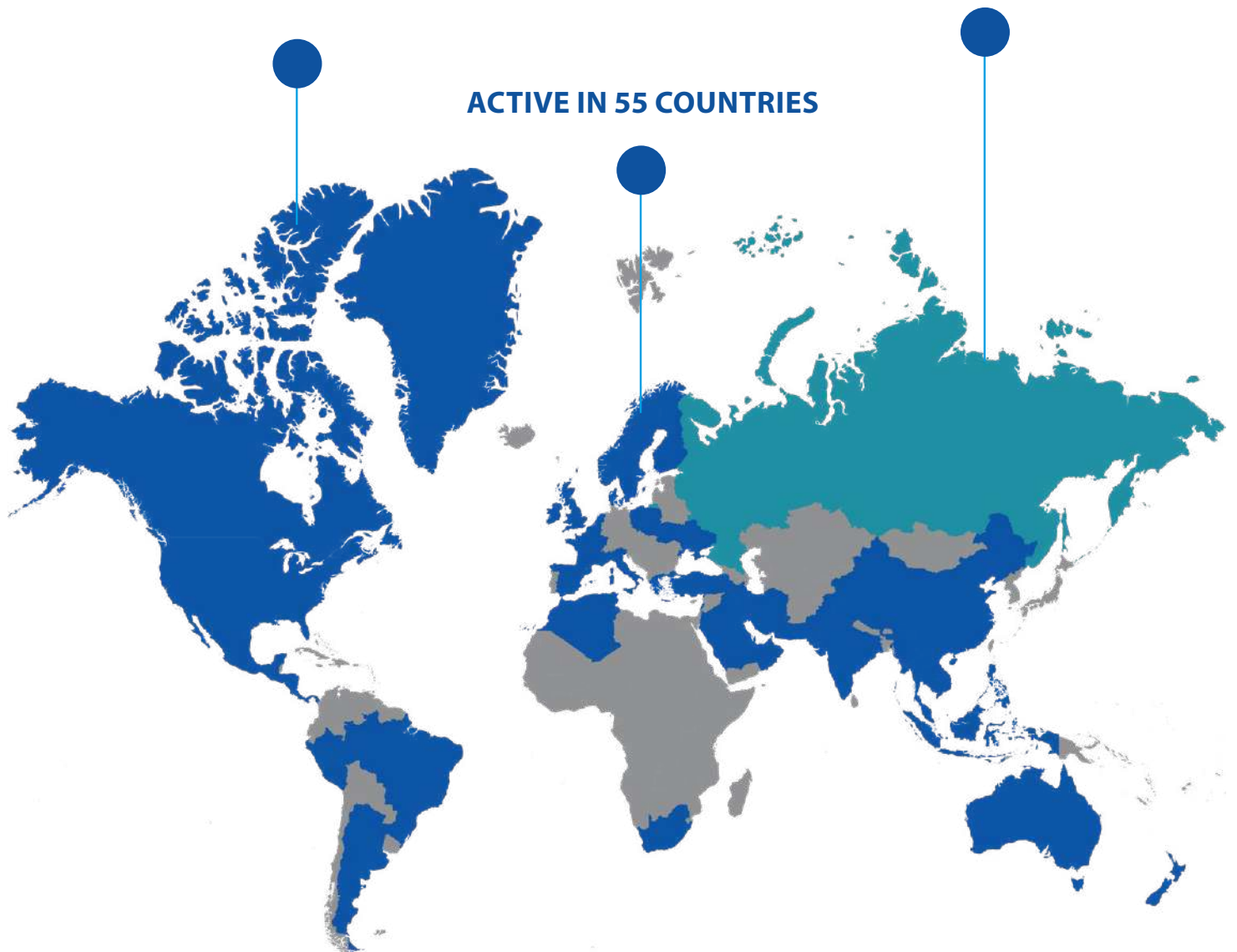

Our Global Agents & Distributors

Australia



Jamie Culpitt
Mobile: +61 432 605 627
E-mail: jamie@focustrading.com.au
Website: www.focustrading.com.au

Darryl Russ
Mobile: +61 459 261 052
E-mail: darryl@focustrading.com.au

Algeria



Tobias Marc Madsen
Mobile: +45 31 43 09 06
E-mail: tobias.madsen@scansteelfoodtech.com

Argentina



Maximiliano Vigliola
Mobile: +54 911 40515947

Bahrain



Philip K. Koshy
Mobile: +971 (0)56 535 4849
E-mail: ceo@fpt-me.com
Website: www.fpt-me.com

Babu Puthoor
Mobile: +971 (0)54 447 4163
E-mail: pm@fpt-me.com

Belgium



Harry Jorissen
Mobile: +31 (0) 6 11867762
E-mail: harry@vertec.nl
Website: www.vertec.nl

Brazil



Antonio Carlos Filleti
Mobile: +55 11 98331-0887
E-mail: antonio.filleti@fimach.com.br
Website: www.fimach.com.br

Cambodia



Axel Arras
Mobile: +66 (0) 81927-4346
E-mail: axel.arras@fpt-asia.com

Surarit Boonyapredee (Yod)
Mobile: +66 (0) 81-414-6667
E-mail: sales.rep@fpt-asia.com

Website: fpt-asia.com

Canada



Aaron Chabino
Phone: +1 816-880-9321
E-mail: achabino@scanamcorp.com
Website: www.scanamcorp.com

Barry France
Phone: +1 816-715-0165
E-mail: bfrance@scanamcorp.com

Our Global Agents & Distributors

China



Jane Zhu
Mobile: +86-150 9528 4001
E-mail: jane.zhu@h-plus.net

Peter Sun
E-mail: peter.sun@h-plus.net

Costa Rica



Pedro Vargas P.
Telephone: +506 2430 4875
Mobile: +506 8821 8487
E-mail: pvargas@monitrolcr.com

Denmark



Bjarne Hvolbøll
Mobile: +45 20 31 38 65
E-mail: bh@nemco.dk
Website: www.nemco.dk

El Salvador



Pedro Vargas P.
Telephone: +506 2430 4875
Mobile: +506 8821 8487
E-mail: pvargas@monitrolcr.com

Finland



Pertti Laurila
E-mail: pla@nemco.fi
Website: www.nemco.fi

Bjarne Hvolbøll
Mobile: +45 20 31 38 65
E-mail: bh@nemco.dk

France



Vincent Lefebvre
E-mail: v.lefebvre@bfrsystems.com
Website: www.bfrsystems.com

Greece



Evangelos Ioannides
Mobile: +30 697 225 0701
E-mail: evangelos.ioannides@iosd.gr
Stergios Lentis
Mobile: +30 698 116 7394
E-mail: sales@iosd.gr

Vasilis Tsirikas
Mobile: +30 697 339 8202
E-mail: sales2@iosd.gr

Greenland



Per Birkholm
Mobile: +45 51 73 02 52
E-mail: per.birkholm@scansteelfoodtech.com

Our Global Agents & Distributors

Guatemala



Pedro Vargas P.
Telephone: +506 2430 4875
Mobile: +506 8821 8487
E-mail: pvargas@monitrolcr.com

Honduras



Pedro Vargas P.
Telephone: +506 2430 4875
Mobile: +506 8821 8487
E-mail: pvargas@monitrolcr.com

Indonesia



Desmond Cheong
Mobile: +65 8321 9233
E-mail: pms@fpt-asia.com

Website: fpt-asia.com

Ireland



Chris Keenan
Mobile: +44 (0) 788 155 1420
E-mail: ck@omori.eu
Website: www.omori.eu

Israel



Raz Pessach
Mobile: +972 (0) 52 6440 318
E-mail: raz@pessach.net
Website: www.pessach.net

Italy



Marco Alessandro Weiss
Mobile: +39 059 460012
E-mail: m.weiss@techpartnersrl.it
Website: www.techpartnersrl.com

Andrea Gasparini
Mobile: +39 327 2028094
E-mail: a.gasparini@techpartnersrl.it

Kuwait



Philip K. Koshy
Mobile: +971 (0)56 535 4849
E-mail: ceo@fpt-me.com
Website: www.fpt-me.com

Babu Puthoor
Mobile: +971 (0)54 447 4163
E-mail: pm@fpt-me.com

Laos



Axel Arras
Mobile: +66 (0) 81927 4346
E-mail: axel.arras@fpt-asia.com

Website: fpt-asia.com

Surarit Boonyapreddee (Yod)
Mobile: +66 (0) 81-414-6667
E-mail: sales.rep@fpt-asia.com

Our Global Agents & Distributors

Malaysia



Desmond Cheong
Mobile: +65 8321 9233
E-mail: pms@fpt-asia.com

Website: fpt-asia.com

Mexico



Per Birkholm
Mobile: +45 51 73 02 52
E-mail: per.birkholm@scansteelfoodtech.com

Morocco



Tobias Marc Madsen
Mobile: +45 31 43 09 06
E-mail: tobias.madsen@scansteelfoodtech.com

Myanmar



Axel Arras
Mobile: +66 (0) 81927 4346
E-mail: axel.arras@fpt-asia.com

Website: fpt-asia.com

Surarit Boonyapreddee (Yod)
Mobile: +66 (0) 81-414-6667
E-mail: sales.rep@fpt-asia.com

Namibia



Per Birkholm
Mobile: +45 51 73 02 52
E-mail: per.birkholm@scansteelfoodtech.com

The Netherlands



Harry Jorissen
Mobile: +31 (0) 6 11867762
E-mail: harry@vertec.nl
Website: www.vertec.nl

New Zealand



Sandie Hussey
Telephone: +64 929 4023
Email: sandie@foodmis.co.nz
Website: www.foodmis.co.nz

Nicaragua



Pedro Vargas P.
Telephone: +506 2430 4875
Mobile: +506 8821 8487
E-mail: pvargas@monitrolcr.com

Our Global Agents & Distributors

Norway



Odd Breigutu
Phone: +47 22 91 44 03
E-mail: odd@bokken.no
Website: www.bokken.no

Oman



Philip K. Koshy
Mobile: +971 (0)56 535 4849
E-mail: ceo@fpt-me.com
Website: www.fpt-me.com

Babu Puthoor
Mobile: +971 (0)54 447 4163
E-mail: pm@fpt-me.com

Panama



Pedro Vargas P.
Telephone: +506 2430 4875
Mobile: +506 8821 8487
E-mail: pvargas@monitrolcr.com

Papau New Guinea



Jamie Culpitt
Mobile: +61 432 605 627
E-mail: jamie@focustrading.com.au
Website: www.focustrading.com.au

Peru



Per Birkholm
Mobile: +45 51 73 02 52
E-mail: per.birkholm@scansteelfoodtech.com

Philippines



Melvin G. Nebria
Mobile: +63917 863 5258
E-mail: sm@fpt-ph.com
Website: fpt-asia.com

Poland



Marcin Królicki
Mobile: +48 601 150 997
E-mail: m.krolicki@premac.pl
Website: www.premac.pl

Qatar



Philip K. Koshy
Mobile: +971 (0)56 535 4849
E-mail: ceo@fpt-me.com
Website: www.fpt-me.com

Babu Puthoor
Mobile: +971 (0)54 447 4163
E-mail: pm@fpt-me.com

Our Global Agents & Distributors

Russia



Alexander Bobrow
E-mail: aab@foodpromtech.ru
Website: www.foodpromtech.ru

NOTE: ALL BUSINESS ACTIVITY ON HOLD

Saudi Arabia



Philip K. Koshy
Mobile: +971 (0)56 535 4849
E-mail: ceo@fpt-me.com
Website: www.fpt-me.com

Babu Puthoor
Mobile: +971 (0)54 447 4163
E-mail: pm@fpt-me.com

Singapore



Desmond Cheong
Mobile: +65 8321 9233
E-mail: pms@fpt-asia.com
Website: fpt-asia.com

South Africa



Per Birkholm
Mobile: +45 51 73 02 52
E-mail: per.birkholm@scansteelfoodtech.com

Spain



Javier Lopez
Mobile: +34 667 669 556
E-mail: javier@picsl.es
Website: www.picsl.es

Xevi López
Mobile: +34 634 622 041
E-mail: xevi@naxindustrias.es

Sri Lanka



Leonard Edirisinghe
Mobile: +94 (0) 77 8804125
E-mail: sl@fpt-asia.com
Website: fpt-asia.com

Sweden



Peo Blomqvist
Mobile: +46 (0)706 010 111
E-mail: pb@nemco.se
Website: www.nemco.se

Thailand



Axel Arras
Mobile: +66 (0) 81927-4346
E-mail: axel.arras@fpt-asia.com
Website: fpt-asia.com

Surarit Boonyapredeedee (Yod)
Mobile: +66 (0) 81-414-6667
E-mail: sales.rep@fpt-asia.com

Our Global Agents & Distributors

scansteel[®]
foodtech

Tunisia



Tobias Marc Madsen
Mobile: +45 31 43 09 06
E-mail: tobias.madsen@scansteelfoodtech.com

Türkiye



Bahadır Kabasakal
Telephone: +90 532 737 19 29
E-mail: bahadir@albateknik.com
Website: www.albateknik.com

Ukraine



Olexiy B. Kolodchenko
Mobile: +38 067 5061112
E-mail: olexiy@steiner.com.ua
Website: www.steiner.com.ua

United Arab Emirates



Philip K. Koshy
Mobile: +971 (0)56 535 4849
E-mail: ceo@fpt-me.com
Website: www.fpt-asia.com

Babu Puthoor
Mobile: +971 (0)54 447 4163
E-mail: pm@fpt-me.com

United Kingdom



Chris Keenan
Mobile: +44 (0) 788 155 1420
E-mail: ck@omori.eu
Website: www.omori.eu

USA



Aaron Chabino
Phone: +1 816-880 9321
E-mail: achabino@scanamcorp.com
Website: www.scanamcorp.com

Barry France
Phone: +1 816-715-0165
E-mail: bfrance@scanamcorp.com

Vietnam



Nguyen Ngoc Duong
Mobile: +84(0) 907 054 786
E-mail: cmo.vn@fpt-asia.com

Website: www.fpt-asia.com

Layout

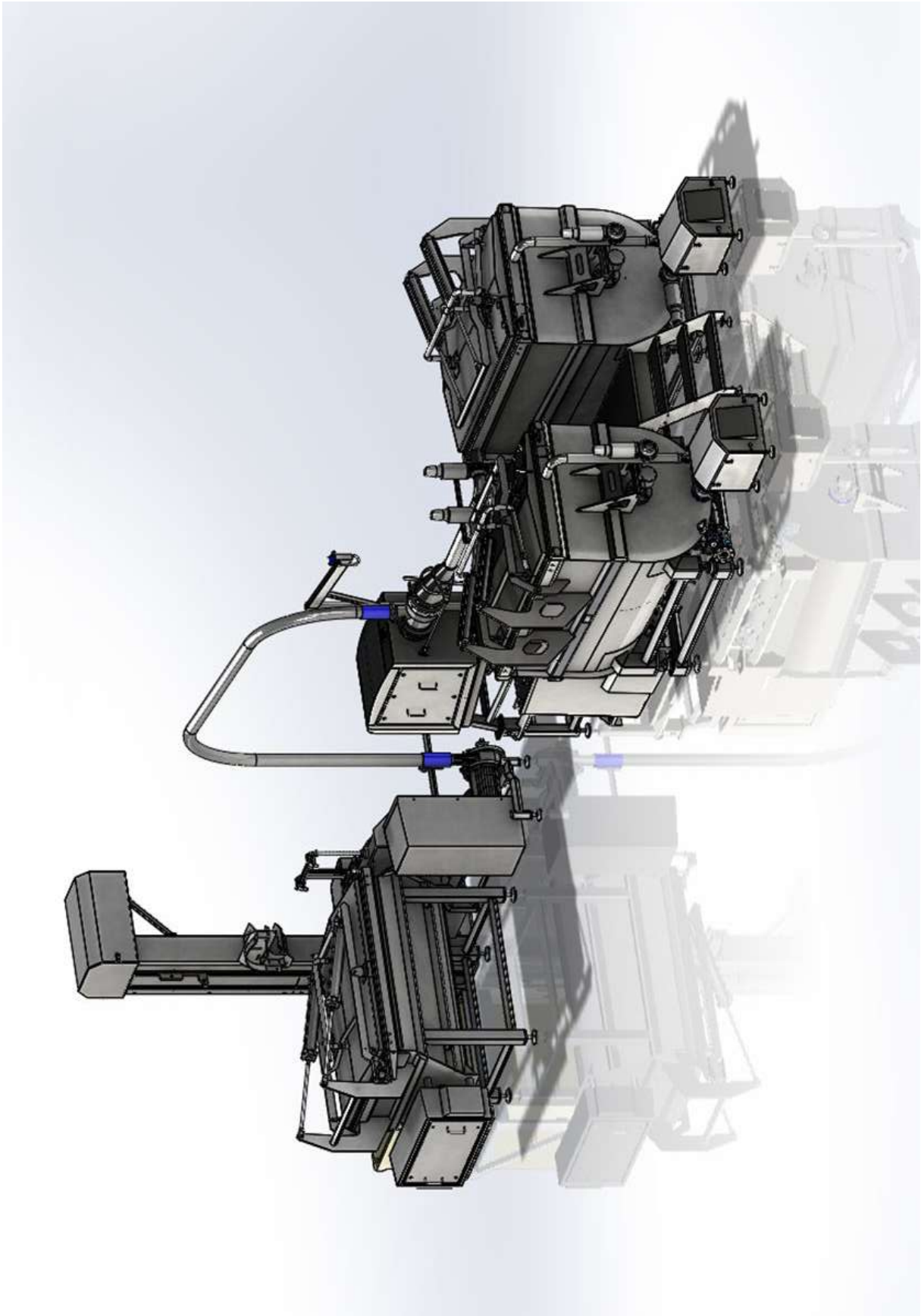

Customer Notes



10,450 m² factory in Denmark, Headquarters of: scansteel foodtech A/S & Koncept Tech ApS

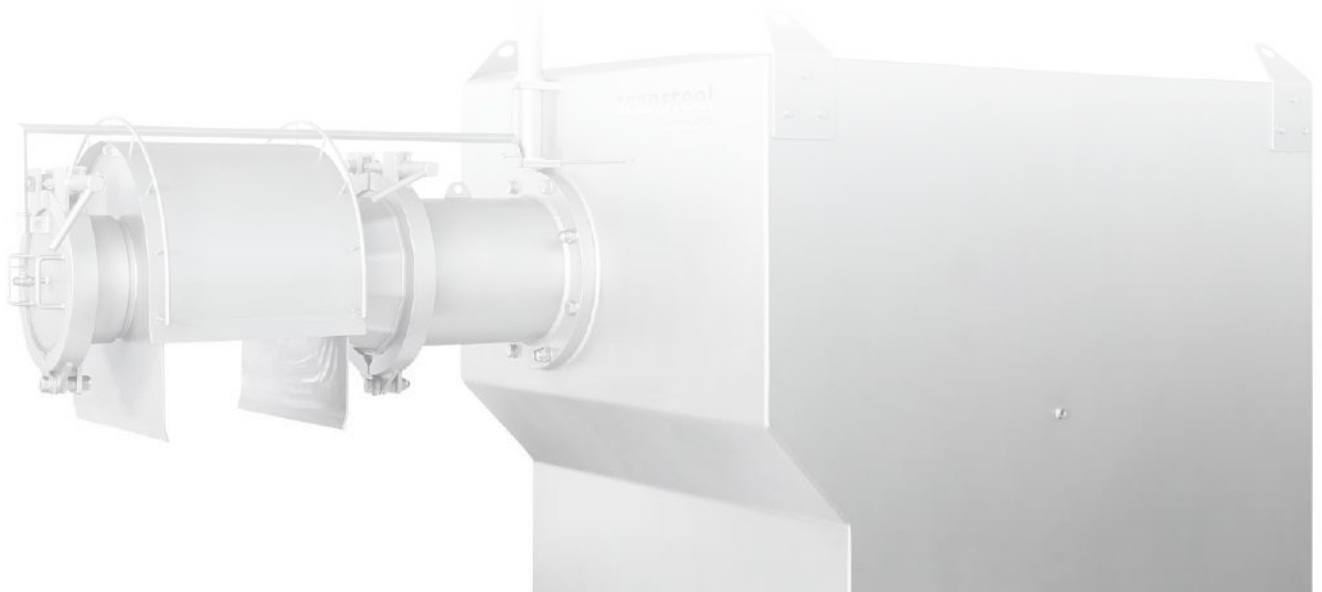

March 2024 Edition

Follow us on Social Media



scansteel foodtech



scansteel foodtech A/S



scansteel foodtech

scansteel foodtech A/S

Industrivej 6
4200 Slagelse
Denmark

Phone: +45 7027 1410

Fax: +45 7027 1411

www.scansteelfoodtech.com